

Packing and Packaging Guidelines

Tens of Thousands of cartons are received daily in each of our service centers. In order to expedite the receiving of these cartons and maintain a high level of accuracy in processing, the following guidelines have been established:

- Packing cartons must be clean corrugated cardboard and must adhere to established size standards. Refer to page 6 – 4
- For footwear packing corrugate must be a minimum of 32 lbs/in ECT and be clean corrugated cardboard
- For apparel, the packing corrugate must be a minimum of 29 lbs/in ECT.
- The weight of each carton must not exceed 50 pounds.
 - The vendor should work with the buyer to ensure that no orders are written that lead to cartons exceeding 50 pounds
- **Guideline:** Footwear cartons should not exceed:
 - 4.1 pounds per pair (including shoe box) for a 12 pair case
 - 5.5 pounds per pair for a 9 pair case
 - 2.8 pounds per pair for a 18 pair case
 - 2.1 pounds per pair for a 24 pair case
- Carton inserts must be placed above apparel merchandise to protect the contents from knife cuts when opened
- Packing cartons must be sealed with **quality security tape** to prevent cartons from being tampered. Security tape must show some type of wording or design on the tape (Recommend 3-inch wide and 2.1 mil thick)
- Cartons are to be sealed with tape only - no binding, straps, staples or glue on cartons
- Cartons containing glass or breakable items must be marked with a “**fragile**” label
- Liquid products require a plastic seal around the cap
- We require a letter from vendors certifying their packaging complies with United Nations “Performance Oriented Packaging” (POP) requirements of HazMat goods (as appropriate)
- Merchandise should be packed with only one SKU / size per master (outer) carton
 - The exception to this would be for small quantities of physically small-sized items, when this is done, each SKU must be listed on the outside of the master (outer) carton. The other exception is direct-to-store or Mark-For / Ship-To orders.
 - Only pack one size per carton unless specified differently on the purchase order (i.e., caselots, multi-packs, direct-to-store, Mark-For / Ship-To)
- **For Bin Orders Only:** Each individual clothing item **must be packaged in a sealed, durable polybag** (polyethylene protection). A UPC barcoded sticker must be placed on the outside of the polybag for automatic fixed scanning.
- **Unless authorized by our buyers and specified on the PO**, individual clothing items should not be placed on hangers. Merchandise placed on hangers might be subject to damage in shipping and handling from the vendor to the service center and from the service center to the stores.
- Merchandise processed via our tilt tray are scanned by their bin/caselot labels. To prevent the problem of multiple barcodes being scanned at the same time, all items packaged in polybags must be packed so that the upc price tickets show on one side of the polybag while the bin/caselot label must show on the opposite polybag side. Hiding the UPC price tickets so that they are not visible through the bag will also prevent the multiple barcodes issue. Additionally, bin/caselot labels must be at the central area of the sealed side of the polybag.

– Special Packing & Packaging Guidelines – Hats & Caps

Hats and caps can easily be damaged when the appropriate packing procedures are not followed.

Recommendation for packing hats and caps:

- Use divider partitions to divide master carton into sections as needed for strength
- Hats should be polybagged in pre-packs per the PO when written as caselots or multi-pack and individually polybagged when written as bin/solid (as per the PO)
- All polybags should be sealed with tape
- SKU’s/styles cannot be mixed within the same master carton

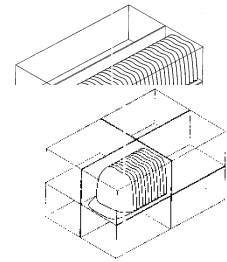

Requirements for Shoe Boxes

Each shoebox must have a finger hole on the lid or bottom of each box. This hole should be a full circle on the lid edge or bottom edge (center). This will appear as a half circle looking from the top of the box and a half circle looking from the label end of the box.

- The box should be of a good grade cardboard
- The box should not be of a slick coating that will make the box hard to handle
- The lip of the lid should extend over the top of the carton at least two inches of the width of the box
- Shoes must not be able to fall out when they are picked up

FOOTWEAR

All footwear shoeboxes are required to be labeled with UPC-A labels or EAN. The barcode height must be a minimum of 12 millimeters and must be ANSI/CEN/ISO grades A or B.

The barcode must be on the lower front of the shoebox and in no way be obscured by the lid of the shoebox. All shoeboxes must have attached lids.

APPAREL

All Bin and Caselot apparel items must be folded so that they fall within the following dimensional guidelines for our tilt tray sortation system. Also, all bin and caselot apparel items must meet the weight requirements noted below. Each individual item is required to be labeled with a UPC-A hangtag. The UPC label barcode height must be a minimum of 12 millimeters and must be ANSI/CEN/ISO grades A or B. The range of dimensions and weight is as follows:

	MINIMUM		MAXIMUM	
	IMPERIAL	METRIC	IMPERIAL	METRIC
WEIGHT	.2 lbs.	0.09 kg	10 lbs.	4.5 kg
LENGTH	3.5 in	8.9 cm	23.0 in	58 cm
WIDTH	3.5 in	8.9 cm	18.0 in	46 cm
HEIGHT	0.5 in	1.3 cm	9.75 in	25 cm

Bin:

Each individual item must be folded per our guidelines and packaged in a sealed, durable polybag. Each item must be ticketed with a retail UPC hangtag. Also, a separate UPC label must be applied to the center of the polybag. When sealing the polybag, the taped end must be on the same side as the UPC label.

Caslot Inner-packs:

Each individual clothing item must be ticketed and folded per our guidelines and the units of each inner-pack packaged together in a sealed, durable polybag. An Interleaved 2 of 5 caslot label must be applied to the center of the polybag. The retail UPC hangtags must not be visible. When sealing the polybag, the taped end must be on the same side as the Caslot label. The Interleaved 2 of 5 caslot label barcode height must be a minimum of 12 millimeters and must be ANSI/CEN/ISO grades A or B.

ACCESSORIES

Each individual item is required to be labeled with a UPC-A hangtag (US Divisions only). The UPC label barcode height must be a minimum of 12 millimeters and must be ANSI/CEN/ISO grades A or B.

Bin

Each individual accessory item must be ticketed with a UPC-A hangtag or UPC-A price label. Also, a UPC label must be applied to the center of the polybag. The UPC label barcode height must be a minimum of 12 millimeters and must be ANSI/CEN/ISO grades A or B

When sealing the polybag, the taped end must be on the same side as the UPC label.

Caslot Inner-packs:

Each individual accessory item must be ticketed per our guidelines and the units of each inner-pack packaged together in a sealed, durable polybag. The retail UPC hangtags must not be visible. An Interleaved 2 of 5 Caslot label must be applied to the center of the polybag. When sealing the polybag, the taped end must be on the same side as the Caslot label. The Interleaved 2 of 5 caslot label barcode height must be a minimum of 12 millimeters and must be ANSI/CEN/ISO grades A or B.

Master (Outer) Carton Size Guidelines

JUNCTION CITY & MILTON MASTER (OUTER) CARTON SIZES						
	MINIMUM		IDEAL		MAXIMUM	
	IMPERIAL	METRIC	IMPERIAL	METRIC	IMPERIAL	METRIC
WEIGHT	3 lbs.	1.36 kg	35 lbs	15.9 kg	50 lbs	22 kg
LENGTH	12 in	31 cm	24 in	61 cm	30 in	76 cm
WIDTH	12 in	31 cm	18 in	46 cm	20 in	51 cm
HEIGHT	7 in	17.78 cm	14 in	35 cm	15 in	38 cm

The Master Carton height cannot be greater than the length not the width to ensure stability on pallets and conveyors.

Shipping Label

The UCC 128 (GS1-128) label must be placed on the bottom right hand corner of the long side of the master (outer) carton approximately 1 inch from the bottom and 1” from the edge.

Any other labels with SSCC-18 barcodes (GS1-128) must have the barcode covered or defaced to make them unscannable.

Packing & Labeling Guidelines

All vendors should file for their UCC identification numbers.

Caslot / Multi-Packs

In addition to caselot requirements, multi-packs require the following:

- Each inner package (polybag or carton) must be sealed with tape
- Each inner package must bear a caselot sticker (see page 6-7)
- The caselot sticker must be placed in the center of the inner pack

For definitions of “caselot” and “multi-pack” see *Section 15–Glossary of Terms*, pages 15–1 and 15–2.

Packaging & Labeling Guidelines (cont.) – Bin/Solid

The UCC 128 label must be placed on the bottom right hand corner of the long side of the master (outer) carton approximately 1 inch from the bottom and 1” from the edge.

Any other labels with SSCC-18 barcodes (GS1-128) must have the barcode covered or defaced to make them unscannable.

Cartons of the same PO / SKU / Size must be uniform quantities. The exception would be the last carton if an odd number of units were ordered.

Bin/Solid Master Carton Illustration (Example of Footwear)

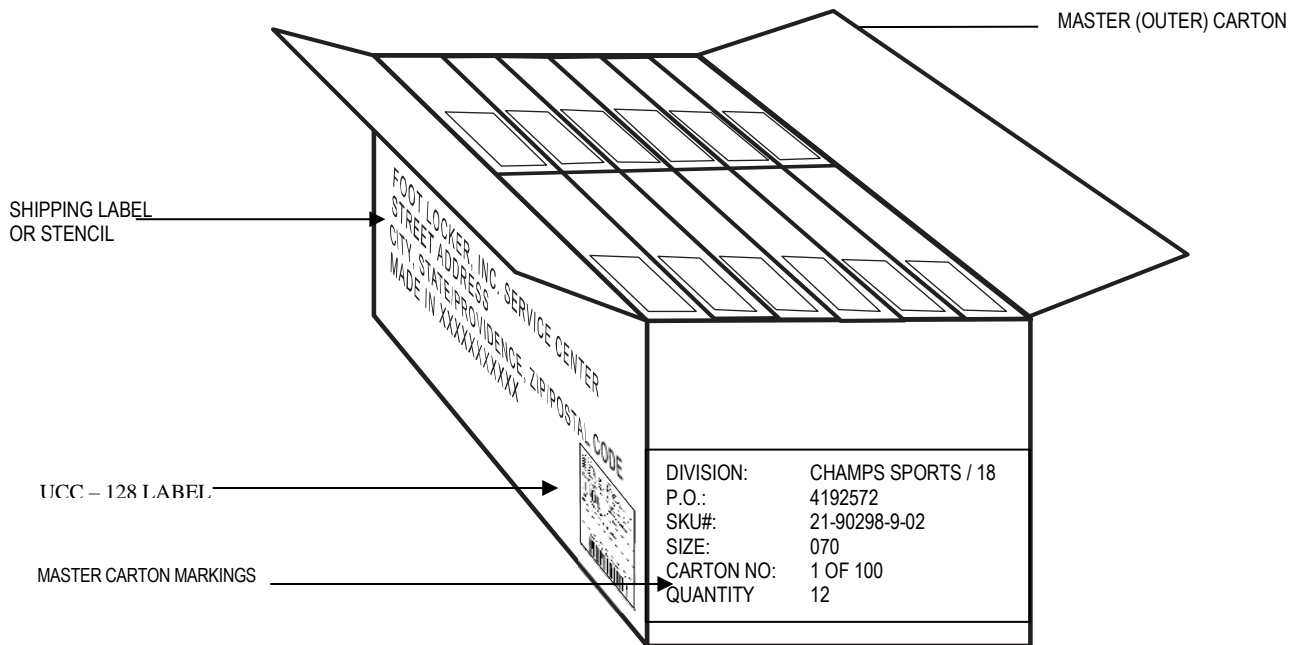

Master Carton Illustration – Footwear - Caselot

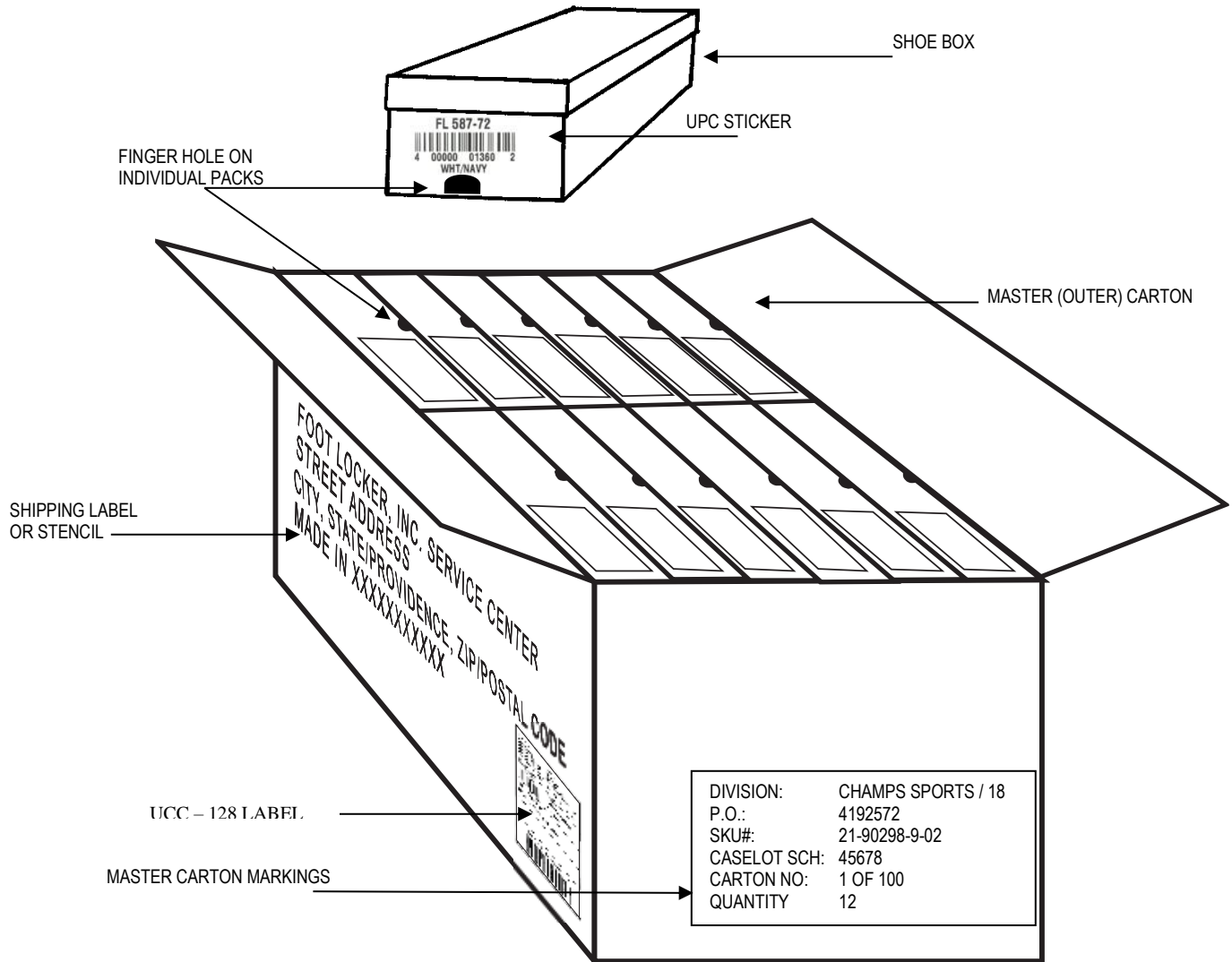

Packaging & Labeling Guidelines (cont.) – Caselot and Multi-Pack

A UCC-128 carton label must be on the outside of each master carton

- A bar coded sticker identifying SKU and caselot size schedule number (Caselot Sticker) on every caselot inner pack polybag.

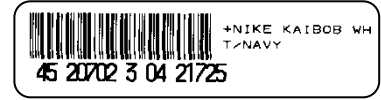

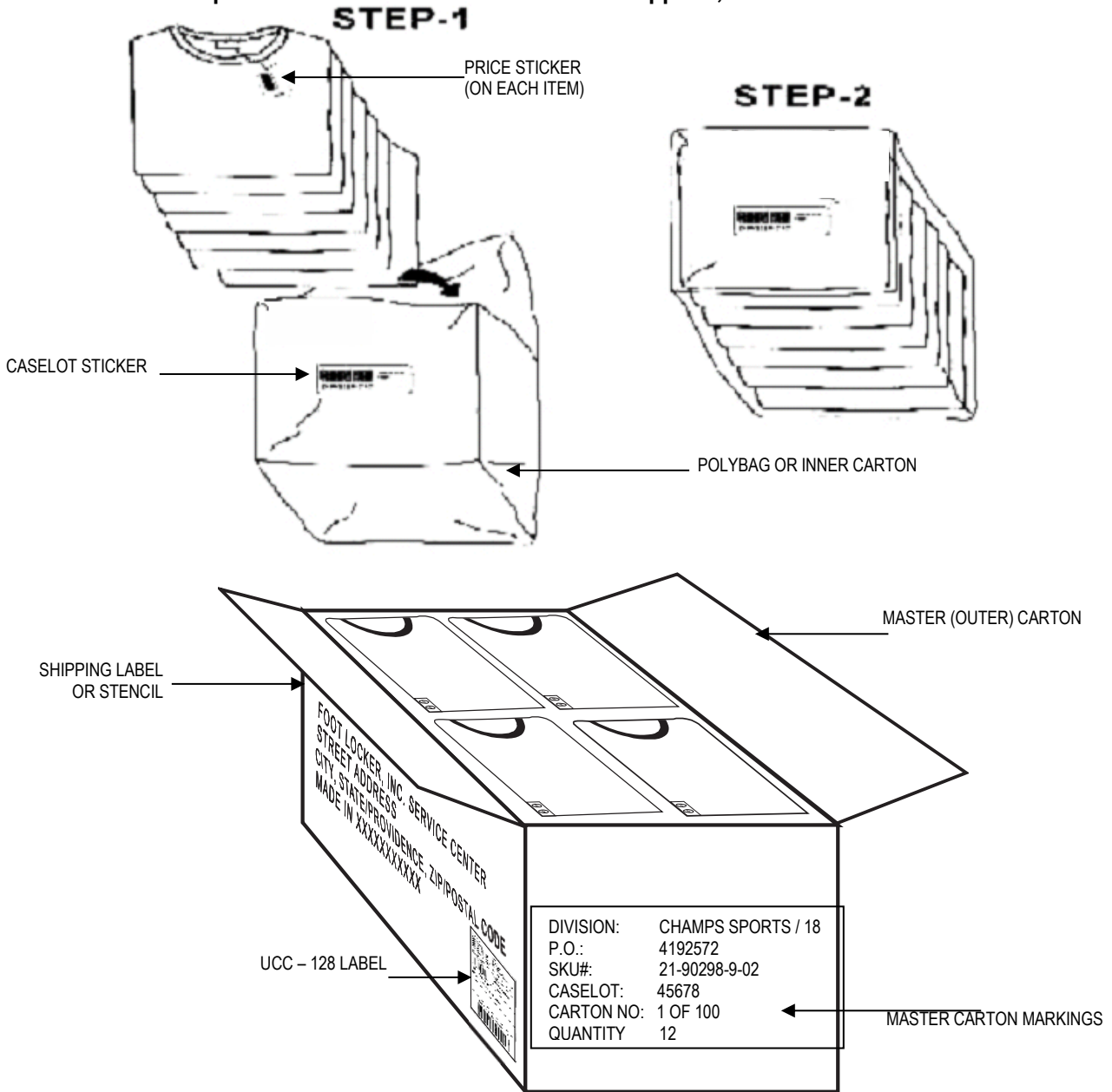

Caselot/Multi-pack Master Carton Illustration – Most Apparel, Accessories and Hard Goods



UCC-128 (aka GS1-128) Common Shipping Label – SSCC

Any other labels with SSCC-18 barcodes (GS1-128) must have the barcode covered or defaced to make them unscannable.

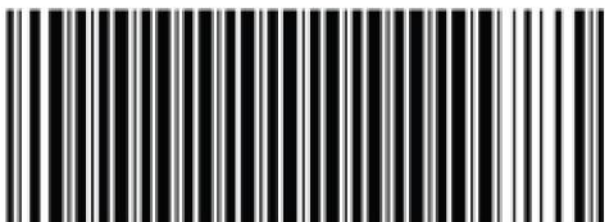
SHIP FROM/ EXPEDIE DE: A SHABET APPAREL INC. 4567 APPAREL ST. NEW YORK, NEW YORK 10018	CARRIER/TRANSPORTEUR B
SHIP TO/ EXPEDIE A: C JUNCTION CITY SERVICE CENTER 3210 SOUTH US HIGHWAY 77 JUNCTION CITY, KS 66441	CASE COUNT: D OF
PURCHASE ORDER/BON DE COMMANDE E 5347102 	F
SKU/UGS: 72 40649 6 00 63050 G 	PICK UNITS QUANTITY:/ QTE CUEILLIE: H <div style="border: 1px solid black; height: 40px; width: 100%; margin-top: 5px;"></div>
CASE LPN/NO D'INSC I (00) 0 0012345 000000074 4 	

ZONE	CONTENT
A	Vendors ship from name and address
B	Carrier information (Optional)
C	Retailers ship to name and address
D	Case count
E	Purchase order number with Code 128 or Code 39 Barcode
F	Optional Free zone
G	SKU number plus caselot size schedule or size code with Interleave 2 of 5 Barcode (This Barcode requires a leading suppressed zero)
H	Pick Units quantity (Optional)
I	UCC-128 Serial Shipping Container Code (SSCC-18 Barcode)

NOTE: Vendors must use a font size of at least 18 for the PO and SKU numbers
All barcodes must meet ANSI/CEN/ISO print quality requirements of A or B
The 3rd party ticket providers in section 3 can also be utilized for the UCC-128 Shipping Label

Master (Outer) Carton Marking Requirements

In addition to the shipping label, the following information must be clearly marked on each master (outer) carton. This will normally be a label.

- Division Name and/or Number
- PO Number
- SKU Number (department, stock number, check digit, width/color code)
- Size Schedule or 3-digit size code
- Quantity
- Carton Number (should be consecutive – by PO and SKU number)
- Color (or other appropriate description) – apparel orders only
- Pack Type (solid, caselot or multi-pack)

In Addition:

- **All carton markings should be uniform stencil/print type**
- All cartons containing short packs must be highlighted (Short packs – loose or less than what stencil indicates)
- All cartons containing glass or breakable items must be marked with a “**fragile**” label
- All cartons containing aerosols must be marked on at least one side with “Level ____ Aerosol” with the proper classification entered. (Classifications are 1, 2 or 3)

Master Carton Marking Examples (Stencil/Print Type)

Below and on the following pages we have provided examples of carton markings.

Solid/Bin

DIVISION	FOOT LOCKER #03
PO NUMBER	1234567-03 (03 = DIVISION NUMBER)
SKU NUMBER	12-34567-8-90
SIZE	070
CARTON NUMBER	12 OF 36
COLOR	BLUE (APPAREL)
QUANTITY (PAIRS/UNITS)	12

Do not mix sizes within a case for a solid/bin order. “Color” only necessary for apparel.

Carton Marking Examples (cont.)

The following are examples of how sizes and quantities should be listed for caselots:

Caselot/Run (Musical).....

DIVISION		LADY FOOT LOCKER #08				
PO NUMBER		1234567-08 (08 = DIVISION NUMBER)				
SKU NUMBER		09-87654-3-21				
CASELOT SCHEDULE		45678				
CARTON NUMBER		13 OF 100				
COLOR		BLACK (APPAREL)				
SIZE RUN	SIZE	920	930	950	960	TOTAL
	QTY	001	002	002	001	006
QUANTITY (PAIRS/UNITS)		12				

Note: "Color" only necessary for apparel

Multi-Pack Caselot

DIVISION		FOOT LOCKER #3				
PO NUMBER		4567890-03 (03 = DIVISION NUMBER)				
SKU NUMBER		12-34567-8-90				
CASELOT SCHEDULE		67890				
CARTON NUMBER		13 OF 200				
COLOR		RED (APPAREL)				
SIZE RUN	SIZE	920	930	950	960	TOTAL
	QTY	001	002	002	001	006
UNITS PER PACK		06				
TOTAL PACKS IN CARTON		08				
TOTAL UNITS IN CARTON		48				

Multi-Pack:

- A multi-pack is a group of caselots (pick units) within a master carton
- Multi-packs would be used for most apparel and some types of accessories
- "Multi-Pack" is sometimes but not usually a "PO type"
- Packaging should be polybags (or small cartons) within the master carton
- The vendor must determine which caselot orders logically make sense to pack as multi-packs while staying within the parameters of carton specifications as noted on page 6 - 3

Examples of Caselot Runs:

Footwear

SIZE	050	055	060	065	070	075	080	085	090	095	100	110	120	TOTAL
QTY	1	1	1	2	2	2	2	2	1	1	1	1	1	18

Sized Apparel

SIZE	XS-910	S-920	M-930	L-950	XL-960	TOTAL
QTY	1	3	8	5	1	18

Accessories, One-Size Apparel or Hardgoods

SIZE	990	TOTAL
QTY	6	6

Loading Requirements

- Palletized shipments must be pre-authorized in writing by the Traffic Department and appropriate service center. The exception is LTL shipments.
LTL shipments should be palletized, and Shrink-Wrapped.
If palletized, UCC-128 labels must be readable from outside without breaking down the pallet.
Pallets must not be mixed by PO/SKU unless the amount of cartons for each is small. In this case, cardboard dividers must be placed to separate each PO/SKU
Pallets must be loaded onto the trailer straight so that a forklift may easily retrieve
Pallets going to our Canada distribution center in Milton, Ontario have a maximum height of 60 inches including the pallet, Double stacking is allowed.
- Packing lists must be attached to the lead carton of each SKU
- If shipment is loaded on multiple trailers, a packing list must accompany each trailer indicating purchase orders shipped on each trailer
- Shipments must be loaded by PO and SKU (SKU includes bin size or caselot schedule). Therefore, shipments must be loaded so that cartons of a PO/SKU/Size are together
- Trailers/Containers must be clean of foreign substances prior to loading. The health and safety of our associates is of primary importance to us. Non-compliance of this requirement may subject the vendor and/or carrier to both a penalty plus the costs incurred as a result of non-compliance, such as identification and clean-up of the substance, medical treatment, etc.

**Trailer/Container Loading Diagram
Bin Shipment**

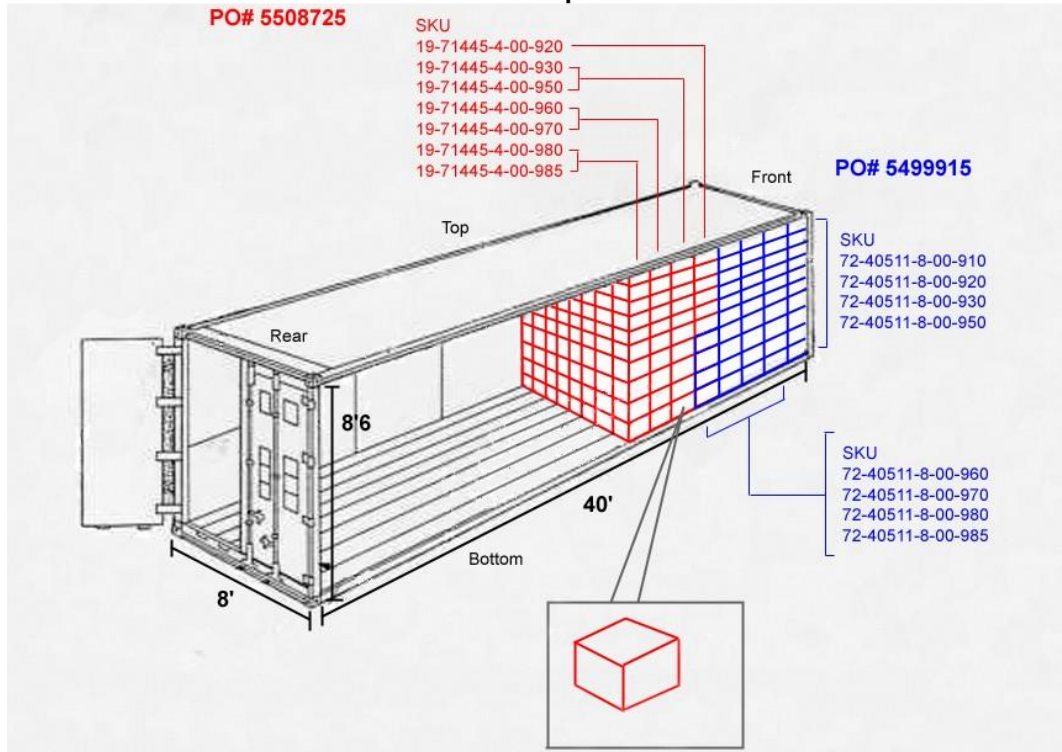

**Trailer/Container Loading Diagram
Caselot Shipment**

